

ST38/ST42

GARDEN TRACTOR AND POWERED SWEEPER COLLECTOR

CODES 150A / 151A / 153A

OPERATOR'S MANUAL

**THIS MANUAL SHOULD BE REGARDED AS PART OF THE
MACHINE, AS IT GIVES ESSENTIAL INFORMATION REGARDING
MACHINE SAFETY, OPERATION AND SPECIFICATIONS.**

ATTENTION



**THIS SYMBOL MEANS
BE ALERT!**

YOUR SAFETY IS INVOLVED

**READ THIS MANUAL BEFORE USING THE ST38/ST42 GARDEN TRACTOR AND
POWERED SWEEPER COLLECTOR. IT IS ESSENTIAL THAT OPERATORS
STUDY IT FOR THEIR OWN SAFETY.**

CONTENTS**Page No.**

SAFETY PRECAUTIONS.	1.6 - 1.12
Training.	1.6
Preparation.	1.6 - 1.7
Operation.	1.7 - 1.8
Maintenance and storage.	1.9
Decals	1.10 - 1.12
EC CONFORMITY INFORMATION.	1.13 - 1.14
EC Declaration of Conformity.	1.13
EC Declaration of Incorporation	1.14
INTRODUCTION.	1.15
SPECIFICATIONS	1.16 - 1.17
Engine	1.16
Detail Specifications	1.16 - 1.17
Weights and Dimensions	1.17
Recommended Lubricants	1.17
OPERATING THE TRACTOR.	1.18 - 1.27
Safety Notice.	1.18
Operator Controls.	1.18
Before Starting the Engine.	1.19
Parking Brake.	1.19
Seat Position.	1.20
Headlights.	1.20
Cutterblade Control.	1.20
Height of Cut Setting.	1.20
Cutterdeck Level Setting.	1.21
Throttle Control.	1.22
Choke Control.	1.22
Travel.	1.22
Ignition Key.	1.22
Fuel Filler Cap.	1.23
Engine Oil Filler Cap.	1.23
Transaxle Bypass Lever.	1.23
Starting and Stopping the Engine.	1.24
Operator Safety System.	1.24

CONTENTS**Page No.**

Sweeper Drive Switch.	1.25
Sweeper Working Height Setting.	1.25
Emptying the Sweeper collector.	1.25
Sweeper Collector Lift Lever.	1.26
Attaching/Detaching the Sweeper Collector.	1.26 - 1.27
MAINTENANCE	1.28 - 1.37
Maintenance	1.28
Engine	1.29
Engine Oil	1.30
Oil Filter	1.30
Fuel and Carburation	1.31
Battery	1.32
Spark Plug	1.32
Headlights	1.32
Electrical	1.32
Tyres and Wheels.	1.33
Lubrication	1.34
Cutterdeck	1.35 - 1.36
Powered Sweeper Collector	1.37
GRASS CUTTING FAULTS.	1.38
TROUBLE SHOOTING.	1.39 - 1.41
ELECTRICAL CIRCUIT DIAGRAM	1.42 - 1.43

READ THIS MANUAL BEFORE USING THE TRACTOR, IT IS ESSENTIAL THAT OPERATORS STUDY IT FOR THEIR OWN SAFETY.



THE FOLLOWING PRECAUTIONS MUST BE TAKEN TO HELP PREVENT ACCIDENTS. A CAREFUL OPERATOR WHO USES COMMON SENSE IS THE SAFEST OPERATOR.

TRAINING



Read the instructions carefully. Be familiar with the controls and the proper use of the equipment. Learn how to stop the tractor quickly in an emergency.



Never allow children or people unfamiliar with these instructions to use the garden tractor and powered sweeper collector. Local regulations may restrict the age of the operator.



Never mow while people, especially children, or pets are nearby.



Keep in mind that the operator or user is responsible for accidents or hazards occurring to other people or their property.



Do not carry passengers.



All drivers should seek and obtain professional and practical instruction. Such instruction should emphasise:

- The need for care and concentration when working with this garden tractor and powered sweeper collector.
- The need to slow down when making tight turning manoeuvres. Failure to take adequate care can affect stability leading to loss of control of the tractor.
- Control of a ride-on machine sliding on a slope will not be regained by application of the brake. The main reasons for loss of control are:
 - Insufficient wheel grip.
 - Being driven too fast.
 - Inadequate braking.
 - The type of machine is unsuitable for the task.
 - Lack of awareness of the effect of ground conditions, especially slopes.
 - Incorrect load distribution.

PREPARATION









While mowing, always wear substantial footwear and long trousers. Do not operate the equipment when barefoot or wearing open sandals. Eye protection should be worn.









Thoroughly inspect the area where the equipment is to be used and remove all objects which can be thrown by the machine.

PREPARATION **Continued.**

-  Warning - petrol is highly flammable:
- Store fuel in containers specially designed for this purpose.
 - Refuel outdoors only and do not smoke while refuelling.
 - Add fuel before starting the engine. Never remove the cap from the tank or add petrol while the engine is running or when the engine is hot. Allow the engine to cool for at least two minutes before refuelling.
 - Do not attempt to start the engine if petrol is spilled or a smell of petrol is present. Move the machine away from the area of the spillage and avoid creating any source of ignition until the petrol vapours have dissipated.
 - Always use fresh fuel. Stale fuel can block the carburettor and cause leakage.
 - Replace fuel tank and oil tank caps securely.
-  Ensure that the cutterdeck is fully raised before transporting the tractor.
-  Replace faulty silencers.
-  Check the condition of the tyres and ensure that they are inflated to the correct pressures.
-  Check that the garden tractor and powered sweeper collector are in good working order, paying particular attention to the brakes and steering. Also ensure that the forward/reverse travel control pedal moves freely to neutral when released.
-  Before use, always visually inspect to see that the blades, blade bolts and cutterdeck assembly are not worn or damaged. Replace worn or damaged components.
-  Check that all linkages, connections and pivot nuts are secure and that wheel nuts are torqued correctly.

OPERATION 

-  Do not operate the engine in a confined space where dangerous carbon monoxide fumes can collect.
-  Mow only in daylight or in good artificial light.
-  Before attempting to start the engine, engage the parking brake, switch off the cutterblade and powered sweeper collector drives and ensure that the forward/reverse travel control pedal is in the neutral position.
-  Watch out for traffic when crossing or near roadways.
-  Use extreme caution when reversing.
-  Switch off the cutterblade and powered sweeper collector brush drives before crossing surfaces other than grass.
-  When using the garden tractor, never direct the discharge of material toward bystanders or allow anyone near the machine while in operation.

OPERATION **Continued.**

 Never operate the garden tractor or powered sweeper collector with defective guards or shields or without safety protective devices in place and in good working order.

 Do not change governor settings to increase the speed of the engine. Operating an engine at excessive speed increases the hazard of injury.

 Before leaving the operator's position:

- Switch off the drive to the cutterblades and powered sweeper collector and lower the powered sweeper collector to the ground.
- Engage the parking brake.
- Stop the engine and remove the ignition key.

 Switch off the drive to the cutterblades and powered sweeper collector, stop the engine and disconnect the spark plug lead or remove the ignition key before:

- Clearing blockages.
- Checking, cleaning or working on the mower or powered sweeper collector.
- Refuelling.
- Removing the powered sweeper collector.
- After striking a foreign object (inspect the mower for damage and make repairs before restarting the tractor).
- If the machine starts to vibrate abnormally check immediately and call dealer if necessary.

 Reduce the throttle setting during engine run out.

 Do not use on a slope of more than **10** degrees.

 Ground conditions affect traction. Particular conditions may not permit safe operation on the slope limits stated.







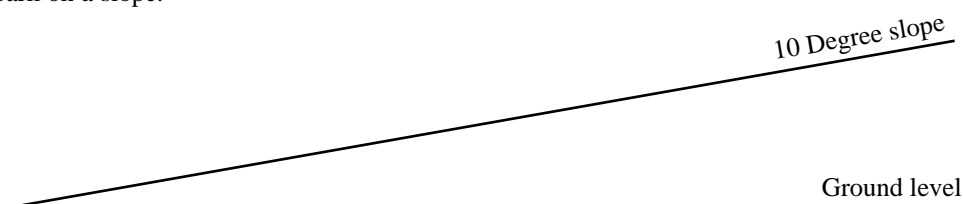





 Remember there is no such thing as a "safe" slope. Travel on a grass slope requires particular care. To guard against overturning:

- Exercise extreme care when changing direction on a slope.
- Do not stop or start suddenly when going up or downhill.
- Engage drive slowly, especially when travelling downhill.
- Tractor speed should be kept low on slopes and during tight turns.
- Stay alert for humps and hollows and other hidden hazards.
- Keep away from sharp inclines and steep drops.
- Never mow across the face of a slope.

 Never park on a slope.



MAINTENANCE AND STORAGE

-  Never store the tractor with petrol in the tank inside a building where fumes may reach an open flame or spark.
-  When the tractor is to be parked, stored or left unattended turn the in-line fuel tap to the closed position, apply the parking brake and remove the ignition key.
-  When the tractor is to be parked, stored or left unattended, raise the cutterdeck to the highest cut height and lower the powered sweeper collector to the ground.
-  Check that all nuts, bolts and screws are tight to be sure the equipment is in safe working condition.
-  Allow the engine to cool before storing in any enclosure.
-  To reduce the risk of fire, keep the engine, silencer, fuel tank and battery compartment free of grass, leaves or excessive grease.
-  Frequently check fuel lines and fittings for cracks or leaks and replace if necessary.
-  Replace worn or damaged parts for safety.
-  Ensure that all safety decals are properly secured and in good condition.
-  If the fuel tank has to be drained, this should be done outdoors.
-  Be careful during adjustment of the machine to prevent entrapment of the fingers between moving blades and fixed parts of the tractor.
-  Never work on the tractor or sweeper collector while the engine is running.

Health and Safety at Work Act:

In accordance with section 6 of the Health and Safety at Work Act 1974, the garden tractor and powered sweeper collector have been designed and constructed so that, in so far as is reasonably practical, they will not endanger the safety and health of those working with them. This is, however, subject to the equipment being properly used and maintained according to the conditions stated in this manual and elsewhere, which have been found necessary as a result of the research and testing of Hayter Limited.

DECALS

Decal - Caution: Hands and Feet Part No: 40-13-010

Location: Cutterdeck.

- a) Warning-Danger of Severing Fingers.
- b) Warning-Danger of Severing Toes.

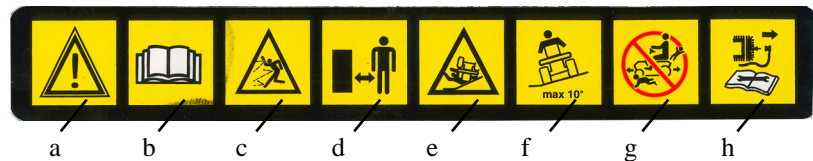
**Decal - General Warning** Part No: MU44x6815

Location: Footwell.

- a) Warning-Safety Alert. Be aware of the possibility of injury.
- b) Carefully read the operator's manual before using the equipment.
- c) Warning-Danger of being hit by thrown objects.
- d) Keep bystanders at safe distances from the tractor during operation.
- e) Warning-Be aware that the tractor can roll over.
- f) Machine rollover. Do not use tractor on slopes of more than 10 degrees.
- g) Do not operate the tractor where children may be present.
- h) Stop the engine and disconnect the spark plug lead or remove ignition key before working on the equipment.

Decal - Drawbar Warning Part No: MU44x6138

Location: Chassis Bulkhead.

- a) Maximum vertical load at rear hitch point.
- b) Maximum horizontal load at rear hitch point.

**Decal - Cutterdeck Drive Belt Routing** Part No: 150037

Location: Cutterdeck.

- a) Drive belt routing.

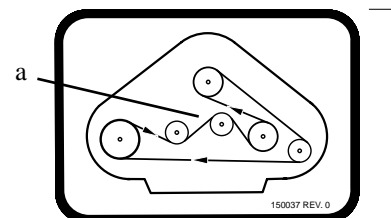

DECALS

Continued.

Decal - Drive Part No: MU710720

Location: Platform RH side.

- a) Forward Travel
- b) Neutral
- c) Reverse Travel

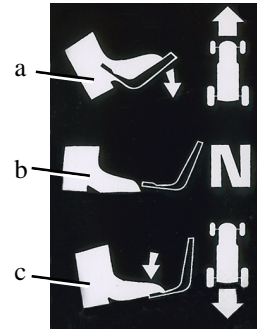

Decal - Transaxle Bypass Lever Part No: 150038

Location: Rear chassis bulkhead.

To Move the tractor by pushing.

- a) Rear axle engaged for operation.
- b) Rear axle disengaged for pushing.

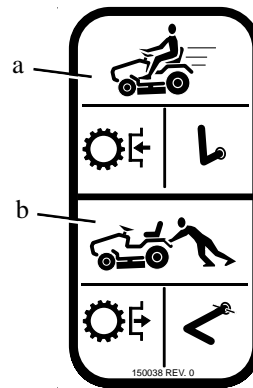

Decal - Level Position Part No: MU44x6456

Location: Platform LH side.

Position for levelling the cutterdeck.



Decal - Height of Cut Part No: MU44x6279

Location: Platform LH side.

Six Height of Cut Settings



DECALS

Continued.

Decal - Powered Sweeper Collector Part No: 153061

Location: LH side adjacent to side belt guard.

- Warning - Danger of hand/arm entanglement - belt drive.
- Do not open or remove belt drive system covers while the engine is running.
- Exposure to thrown or flying objects.
- Keep shield/cover in place while the sweeper is rotating.
- Warning - Danger of hand/arm entanglement - sweeper brush.
- Do not touch the sweeper brush while the engine is running.

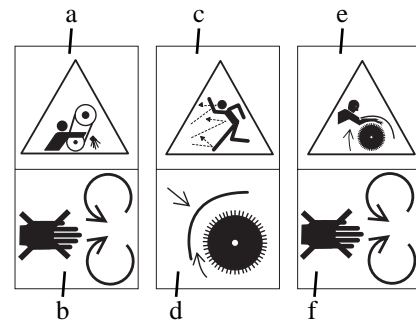
**Decal - Serial Number**

Location: ST38/ST42 Garden Tractors: Under seat.

Location: Powered Sweeper Collector: LH side under belt guard.

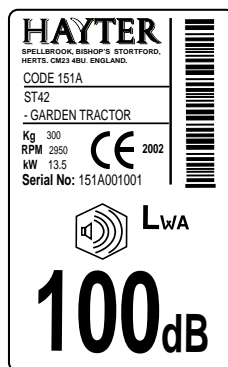
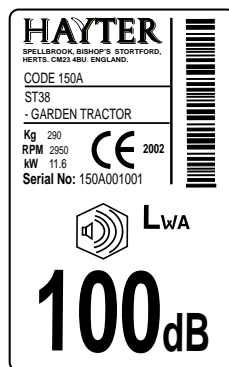

MOULDINGS

Guard - Rear Flap Part No: 150048

Location: Rear chassis bulkhead.

- Warning - Danger of hand/arm entanglement
- Do not open or remove belt drive system covers while the equipment is running.

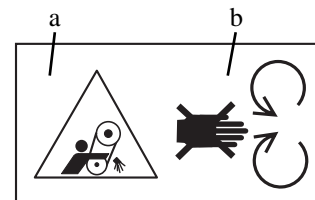

EC DECLARATION OF CONFORMITY

EC DECLARATION OF CONFORMITY

HAYTER LIMITED,
Spellbrook, Bishop's Stortford, Herts CM23 4BU ENGLAND



declare that the lawnmower:

Models:	ST38	ST42
Machine Type No.	CODE 150A	CODE 151A
Category:	Ride-on Lawn Mower	Ride-on Lawn Mower
Type:	Rotary	Rotary
Engine manufacturer:	Briggs & Stratton	Briggs & Stratton
Speed of rotation:	2850 rpm	2850 rpm
Width of cutting device:	956 mm	1065 mm
Speed of rotation of the cutting device:	2550 rpm	2550 rpm

Complies with the provisions of Directive: 98/37/EC Essential Health & Safety Requirements Relating to the Design & Construction of Machinery and Safety Components.

Also Directive 89/336/EEC amended by 92/31/EEC Electromagnetic Compatibility.

Also Directive 2000/14/EC Noise emission in the environment by equipment for use outdoors. (ANNEX VI)

Notified Body: Sound Research Laboratories Ltd. Holbrook House, Little Waldingfield,
Sudbury, Suffolk, ENGLAND

Notified body identification No: 1088

Guaranteed sound power level: 100 dB(A) 100 dB(A)

Standards used: EN292, EN836 and ENISO14982

Authorised Signature

Signed

M.A. Wright
(Technical Director)

Date: 01.03.02.

Technical Documentation Kept at:
HAYTER LIMITED,
Spellbrook, Bishop's Stortford,
Herts CM23 4BU ENGLAND

VIBRATION INFORMATION

Lawnmower vibration information. RMS acceleration measured in 3 - axes at operators contact position

- on the:
- steering wheel does not exceed **2.5ms²**
 - at seat does not exceed **0.5ms²**

EC DECLARATION OF INCORPORATION

EC DECLARATION OF INCORPORATION

HAYTER LIMITED,
Spellbrook, Bishop's Stortford, Herts CM23 4BU ENGLAND

declare that the lawnmower attachment:

Machine Type No.	CODE 153A
Category:	Sweeper Collector
Type:	Rotary Brush

Complies with the provisions of Directive: 98/37/EC Essential Health & Safety Requirements Relating to the Design & Construction of Machinery and Safety Components.

Standards Used: EN292, EN836.

Authorised Signature

Signed



M.A. Wright
(Technical Director)

Date: 01.03.02
Technical Documentation Kept at:
HAYTER LIMITED,
Spellbrook, Bishop's Stortford,
Herts CM23 4BU ENGLAND



WARNING: Under no circumstances can attachments other than those covered by the above EC Declaration of Incorporation or other attachments that may be introduced by Hayter Limited in the future, having a similar EC Declaration, be supplied for or fitted to the Code 150A or Code 151A Garden Tractors. Unauthorised use of other equipment will invalidate the EC Declaration of Conformity and may cause the mowers to be unsafe.

INTRODUCTION

The Hayter Heritage ST38 and ST42 Garden Tractors are petrol engine powered self propelled machines with a belt driven hydraulic transaxle for ground drive, cutterdeck and optional rear powered sweeper collector. The machines operate in two wheel drive.

The Hayter Heritage ST38 and ST42 Garden Tractors are designed solely for use in a domestic grass cutting environment. Use in any other way is considered as contrary to the intended use. Compliance with and strict adherence to the conditions of operation, service and repair as specified in this Operators Manual also constitute essential elements of the intended use. The way in which these machines are operated and maintained will have a profound effect on their performance and reliability.

This manual contains advice on the Hayter Heritage ST38 and ST42 Garden Tractors and optional Sweeper Collector which should be operated, serviced and repaired only by persons who are familiar with their particular characteristics and who are acquainted with the relevant safety procedures.

The safety precautions listed herein and all other generally recognised regulations on safety must be observed at all times.

Any arbitrary modifications carried out to these machines may relieve Hayter Limited of liability for any resulting damage or injury.

Optional Extras: Powered Sweeper Collector

Left and Right: Throughout this manual the terms 'Left' and 'Right' refer to the machine when looking in the direction of forward travel.

This manual is based on information available at the time of publication.

HAYTER LIMITED reserve the right to amend product specifications without prior notification.

ENGINE

Tractor Model:	ST38	ST42
Type:	Briggs and Stratton 15.5 HP Intek Anti-vibration system single cylinder	Briggs and Stratton 18 HP Intek 90° V-Twin
Power Rating:	15.5 HP at 3000rpm	18 HP at 3000rpm
Capacity:	465cc	656cc
Air Cleaner:	Dual Element Air Cleaner	Dual Element Air Cleaner
Cooling System:	Fan Assisted Air Cooled	Fan Assisted Air Cooled
Battery:	12v 35a.h Sealed Lead Acid Battery	12v 35a.h Sealed Lead Acid Battery
Alternator:	16 Amps	16 Amps
Starter:	12v Regular	12v Regular
Cold Starting:	Choke-cable operated by Throttle Control	Choke-cable operated by knob
Idle Speed:	1750 (+/- 100) rpm	1750 (+/- 100) rpm
Fuel Type:	Unleaded Petrol	Unleaded Petrol
Oil Type:	SAE 30 Engine Oil	SAE 30 Engine Oil

IMPORTANT: PREVENT DAMAGE - for further information regarding the engine, refer to - ENGINE MANUAL.

DETAIL SPECIFICATIONS

Tractor Model:	ST38	ST42
Travel Speed:		
Forward:	0-10.5 km/hr (0-6.5mph)	0-10.5 km/hr (0-6.5mph)
Reverse:	0-9 km/hr (0-5.5mph)	0-9 km/hr (0-5.5mph)
Cutting Width:	956mm	1065mm
Cutting Height:	20-90mm	20-90mm
Fuel Tank:	10.5ltr	10.5ltr

DETAIL SPECIFICATIONS

Continued.

Optional Sweeper Collector:	ST38	ST42
Grass Collector Capacity:	250Ltr	250Ltr
Sweeping Width:	695mm	695mm
Sweeper Brush Diameter:	320mm	320mm
Sweeping Height:	0-50mm	0-50mm

WEIGHTS AND DIMENSIONS

Tractor Model:	ST38	ST42
Height:	1100mm	1100mm
Width:	1050mm	1150mm
Length:	2900mm	2900mm
Tractor Weight:	290Kg	300Kg
Optional Sweeper Collector:	ST38	ST42
Height:	80Kg	80Kg
Width:	1110mm	1110mm
Length:	960mm	960mm
Weight:	1220mm	1220mm

RECOMMENDED LUBRICANTS

Grease Points: A good quality medium grease.

Engine: SAE 30 engine oil.

Rear Transaxle: 20w-50 engine oil.

SAFETY NOTICE



WARNING: PREVENT ACCIDENTS - Before operating the equipment it is essential that;

- The operator reads and understands all safety instructions and symbols.
- The operator is familiar with the controls.
- The daily maintenance checks have been properly carried out and the equipment is in good working order.
- The operator should wear safety clothing and eye protection. Failure to do so could result in risk to health and safety.
- The area where the equipment is to be used is inspected and all objects which may be thrown by the mower are removed.
- The operator follows safe working practices when working on slopes.

OPERATOR CONTROLS

1. Sweeper Drive Switch.
2. Throttle Lever with Integral Engine Choke Control (ST38 only).
3. Cutterdeck Drive Switch.
4. Ignition Switch.
5. Parking Brake Latch.
6. Parking Brake Pedal
7. Fuel Filler Cap
8. Engine Oil Filler Cap
9. Forward/Reverse Pedal
10. Sweeper Collector Lift Lever
11. Height of Cut Lever
12. Engine Choke Control Knob (ST42 only)
13. Sweeper Collector Latch Locking Mechanism
14. Steering Wheel.
15. Sweeper Collector Tipping Lever.
16. Sweeper Working Height Lever.
17. Transaxle Bypass Lever.

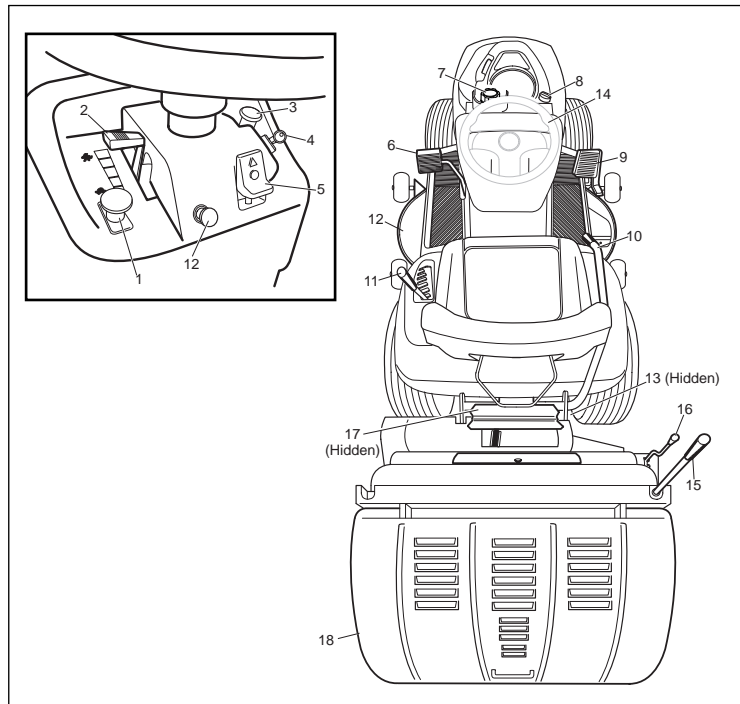

BEFORE STARTING THE ENGINE

Check Oil Level: Note: The engine was filled with oil at the factory.

Oil Type: SAE30 Engine oil, classified for service - 'SF' minimum.

Fuel Type: Always use clean, fresh unleaded petrol. Purchase fuel in quantities that can be used within 30 days. Never mix oil with petrol. For added engine protection, Briggs and Stratton recommend the use of their fuel additive which is available from authorised Briggs and Stratton Service dealers.

Check Fuel Level: Clean around the fuel filler cap before removing it. Do not overfill the tank. Allow 6mm minimum of tank space for expansion.

IMPORTANT: The fuel filler cap must be secured to prevent fuel leakage during operation.

Check Tyres: Check the air pressure in the tyres. Incorrect pressure can cause the unit to ride badly and may prevent the cutterdeck from cutting level.

Axle	Tyre Type	Recommended Tyre Pressures	
		Working Pressure	Max. Pressure
Front Axle	Turf Pro 16 x 6.50 x 8-2ply	0.7 bar (10 P.S.I)	1.0 bar (14 P.S.I)
Rear Axle	Turf Pro 23 x 9.50 x 12-2ply	0.6 bar (8 P.S.I)	0.7 bar (10 P.S.I)

Sweeper/Attachments: Check that the sweeper collector has been attached to the tractor and latched securely. Check that the drive belt is routed correctly around the rear electric clutch pulley on the tractor and the input pulley on the sweeper collector.

PARKING BRAKE

IMPORTANT - Always engage the parking brake when the machine is stationary or left unattended.

Engaging the Parking Brake: Push the brake pedal down and hold while lifting the parking brake latch. Gradually release the pedal. The brake pedal should remain in the depressed (brake engaged) position.

Releasing the Parking Brake: Push down on the brake pedal. The brake pedal latch will disengage automatically. Gradually release the pedal.

SEAT POSITION

The seat can be adjusted forward or backwards. Raise the seat (1), loosen the adjuster knobs (2), adjust the seat to the desired position and re-tighten the adjuster knobs. Lower the seat.

IMPORTANT - Ensure that the adjuster knobs are fully tightened before operation.

1. Seat
2. Adjuster Knobs

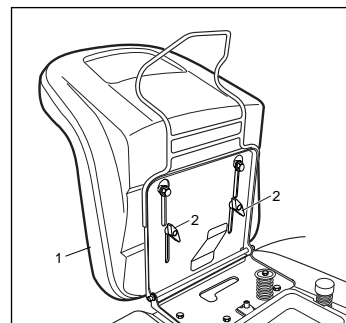

HEADLIGHTS

The lights are an integral function of the ignition switch. Turn the ignition key to the  symbol to switch them on.

CUTTERBLADE CONTROL

The cutterdeck drive switch engages and disengages drive to the cutterblades.

- Engage Drive: Pull the cutterdeck drive switch out.
- Disengage Drive - Push the cutterdeck drive switch in.

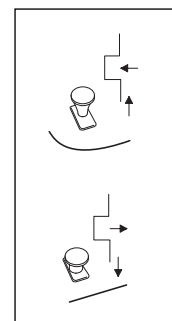

HEIGHT OF CUT SETTING

The height of cut lever is used to raise and lower the cutterdeck to the desired height of cut.

Move the height of cut lever inwards to disengage it from the height of cut notches, then push forwards to lower or pull backwards to raise the height of cut. Release the lever into the required position and ensure that it locks securely into the appropriate notch. There are six height of cut positions. These are indicated by the numbered notches, 1 to 6.

IMPORTANT: Always select the height of cut to suit operating conditions. Prevent engine overloading and blockages by avoiding low cuts in long grass conditions. Be prepared to make two cuts when the grass is long.

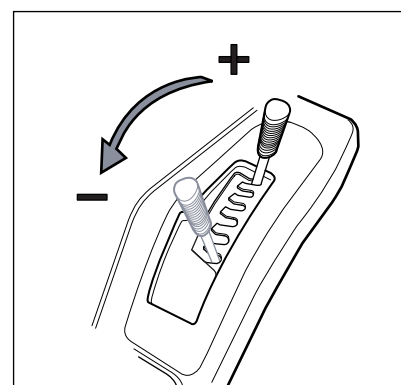

CUTTERDECK LEVEL SETTING

⚠ WARNING: PREVENT ACCIDENTS - Remove the ignition key and disconnect the spark plug lead before making any adjustments.

To level the cutterdeck:

Ensure that the tractor is on a firm and level surface.

Ensure that the parking brake is engaged.

Check that tyre pressures are within prescribed limits.

Ensure that all four cutterdeck anti-scalp wheels are in their highest position.

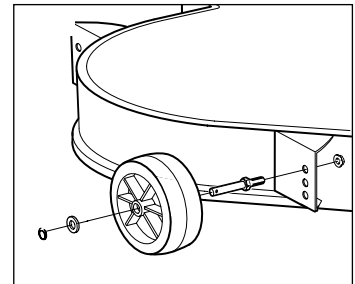

Lift the plastic cover at the base of the height of cut notches to reveal the deck levelling notch

Move the height of cut lever into the deck levelling notch.

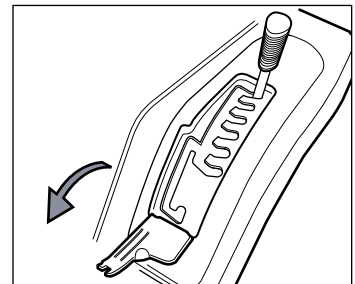

Loosen the primary drive belt to the deck by releasing it from the drive tensioner pulley.

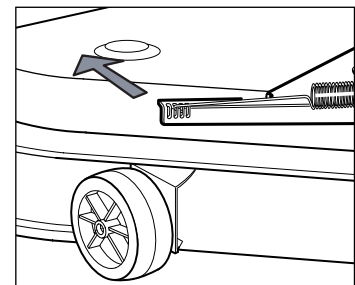

Loosen the left and right wing nuts at the rear and ensure that the four anti-scalp wheels are firmly in contact with the ground. Shake the cutterdeck briskly and briefly in order to ensure that any slackness is removed from the cutterdeck lift linkages. Re-tighten both the left and right wing nuts.

Replace the primary drive belt, ensuring that the tensioner pulley is in position.

Select the desired height of cut and relocate the deck levelling notch cover.

Mow for a short distance. If the height of cut is not level, repeat the cutterdeck levelling procedure.

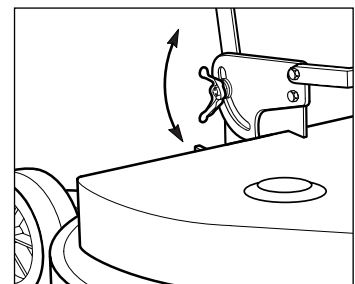

THROTTLE CONTROL

Operate the throttle control in a forward direction to increase engine speed.

Operate the throttle control in a rearward direction to reduce engine speed.

Note that the engine speed will dictate the speed of other functions, i.e. travel and cutterblade speed.

NOTE: It should only be necessary to push the lever to the 'Fast' position before starting a warm engine. Use the choke to start a cold engine.

CHOKE CONTROL

ST38 ONLY: Operate the throttle control lever fully forwards to its stop - this will position the lever in the 'Choke' position.

ST42 ONLY: Pull the choke control knob out - this will engage the choke.

NOTE: Use of the choke should only be necessary before starting a cold engine.

TRAVEL

The throttle control regulates the engine speed. For the best cutting performance, position the throttle control in the 'FAST' position.

Forward Travel: Release the parking brake, and depress the forward travel pedal to increase ground speed. Release the pedal to reduce speed.

Reverse Travel: Depress the reverse travel pedal to increase reverse ground speed. Release the pedal to reduce speed.

Stop (Neutral): Release the travel pedal.

IGNITION KEY

- 0 - Engine Off
- 1 - Lights On
- 2 - Ignition On
- 3 - Start Engine



WARNING: PREVENT ACCIDENTS - Always remove the ignition key when the mower is not in use.

FUEL FILLER CAP

Clean grass and other debris from around the filler cap and neck of the tank before removing the cap for re-fuelling.



WARNING: PREVENT ACCIDENTS - The fuel filler cap must not be removed whilst the engine is running.

IMPORTANT: The fuel filler cap must be secured to prevent fuel leakage during operation.

ENGINE OIL FILLER CAP

Clean grass and other debris from around the filler cap before removing it.

IMPORTANT: The engine oil filler cap should not be removed while the engine is running and must be secured to prevent oil leakage during operation.

TRANSAXLE BYPASS LEVER

IMPORTANT: Always push the tractor by hand. Never tow the tractor as damage may occur.

Park the tractor on a level surface, disengage the cutterdeck drive switch and sweeper drive switch, engage the parking brake and stop the engine.

Locate the transaxle bypass lever on the tractor rear bulkhead (Refer fig.1). Pull the transaxle bypass lever out and twist to engage the pin on the face of the rear bulkhead (Refer fig.2)

Release the parking brake. The tractor is now ready to be pushed.

Re-engage the transaxle drive by reversing the procedure.

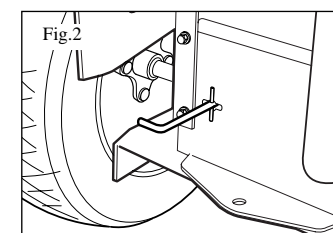
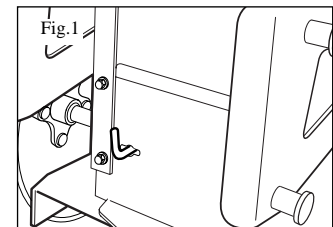

STARTING AND STOPPING THE ENGINE

Starting: Open the fuel shut-off valve located between the fuel tank and the engine. The knob should align with the fuel hose in the open position.

1. Sit on the tractor seat.
2. Ensure that both the cutterdeck and sweeper drive switches are in the 'Off' position and that the parking brake is engaged.

NOTE: The engine will not start if any of the conditions above are not satisfied.

3. Turn the ignition key clockwise and hold it in the 'Start' position. When the engine starts, release the key.

NOTE: It should only be necessary to use the choke before starting a cold engine. Before starting a warm engine, position the engine control lever in the 'Fast' position.

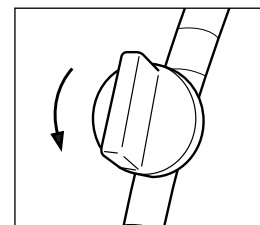

Stopping: Move the throttle lever to the 'Slow' position.

IMPORTANT: To prevent backfiring and damage to the engine, do not move the throttle lever to the 'CHOKE' or 'FAST' positions before stopping the engine.

NOTE: If the engine has been working hard let it idle for a minute before turning the ignition key to "Off".

OPERATOR SAFETY SYSTEM

The operator safety system has been designed to prevent the engine from starting unless:

- The operator is sitting on the seat.
- The parking brake is engaged.
- The cutterdeck drive switch is in the 'Off' position.
- The sweeper drive switch is in the 'Off' position.

The operator safety system has been designed to:

- stop the drive to both the cutterdeck and sweeper collector if the operator rises from the tractor seat.
- stop the engine if the operator rises from the tractor seat **UNLESS** the parking brake is engaged.



WARNING: PREVENT ACCIDENTS - Do not operate the mower if the operator safety system is defective in any way.

IMPORTANT: ALWAYS replace faulty parts and check that they function correctly before operating the tractor.

SWEeper DRIVE SWITCH

The sweeper/collector drive switch engages and disengages drive to the sweeper brush.

Engage Drive - Pull the sweeper drive switch out.

Disengage Drive - Push the sweeper drive switch in.

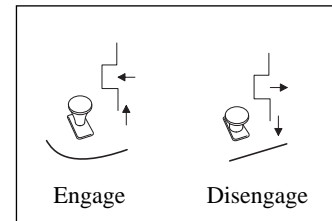

SWEeper WORKING HEIGHT SETTING

The sweeper working height lever is used to raise and lower the sweeper brush to the desired working height.

Move the lever outwards to disengage it from the working height notches, then push forwards to lower or pull backwards to raise the working height. Release the lever into the required position and ensure that it locks securely into the appropriate notch.

There are six working height positions. These are indicated by the numbered notches, 1-6.

IMPORTANT: Always select the working height to suit operating conditions. It is recommended that for optimum collection performance the working height of the sweeper is selected to correspond with the height of cut of the cutterdeck as indicated by the numbers 1-6.

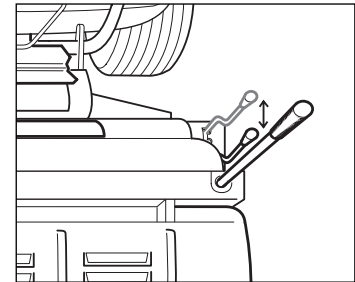

EMPTYING THE SWEEPER COLLECTOR

The viewing hatch in the front of the sweeper collector housing can be used to check if the collector is full. (Refer fig.1)

! WARNING: PREVENT ACCIDENTS - Ensure that the tractor is stationary and the drive to the sweeper is disengaged before emptying the grass collector.

The grass collector can be emptied by extending the tipping lever to its full extent and pulling it forwards. The grass hopper will rotate around its pivots, and allow the grass clippings to empty out. (Refer fig.2)

The floor of the grass collector will lift as the hopper rotates and this assists with emptying. Two cables connecting the floor to the hopper provide this function.

When empty, close the grass collector by allowing the hopper to gently drop down. The collector floor will naturally resume its level position.

Allow the tipping lever to drop back into its fully retracted position.

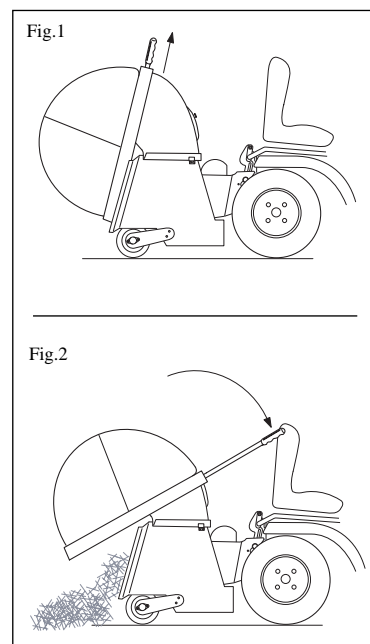

SWEeper COLLECTOR LIFT LEVER

The sweeper collector can be lifted for transport and lowered into work by means of the lift lever situated to the right of the seat.

Raising the lever will lower the sweeper collector to the ground. Allow the lever to fall back until it rests on the front of the sweeper collector housing.

Raise the sweeper/collector into the transport position by pulling the lift lever forwards and down until it reaches its lowest position adjacent to and parallel with the platform.

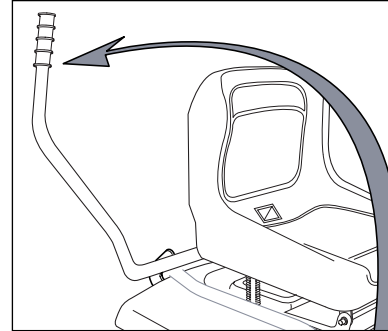

! WARNING: PREVENT ACCIDENTS - When operating the lift lever with the sweeper collector attached to the tractor, be sure to maintain a firm grip on the lever. Inadvertent release of the lever whilst it is in mid-travel could cause sudden movement leading to injury.

ATTACHING/DETACHING THE SWEEPER COLLECTOR

Attaching the sweeper collector:

- Attaching the sweeper collector to the tractor will be easier if both units are on firm, level ground.
- Raise both the tractor seat and the rear guard flap.
- Position the sweeper collector behind the tractor in line with rear lift linkages.
- Operate the sweeper collector lift lever so as to position the lift linkage on the tractor into its lowest position.
- Move the sweeper collector forwards, raising the hooks on the linkage bracket so that they engage the upper pins on the tractor lift linkage brackets (Refer fig. 1)
- Open the sweeper collector latch locking mechanism.

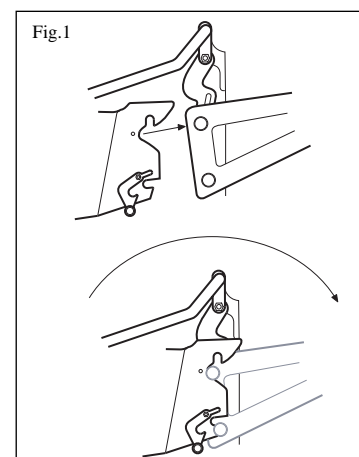

ATTACHING/DETACHING THE SWEEPER COLLECTOR

continued.

- Whilst the sweeper collector is in this position fit the drive belt. Fitment of the belt will be easier if the sweeper collector is pushed forwards so that the upper linkage pins engage the recesses immediately below the linkage hooks.
- Remove the tool tray which is situated under the seat. Place the drive belt over the sweeper clutch and engage into the pulley.
- Fit the drive belt over the sweeper collector input pulley as shown. Ensure that the tensioner pulley is correctly positioned. (Refer fig. 2)
- Using the lift lever raise the sweeper collector into the transport position and engage the latch locking mechanism. (Refer fig. 3)
- Close the rear guard flap.
- Replace the tool tray and lower the seat.

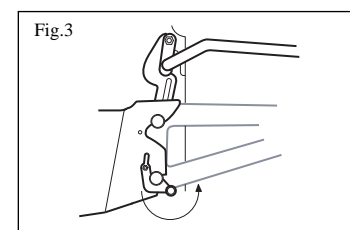
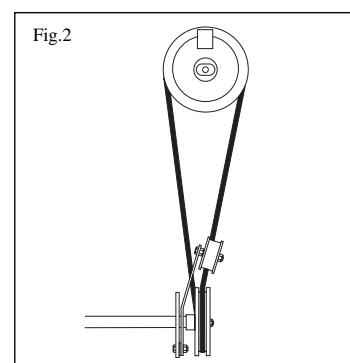

Before operation, the sweeper collector must be securely latched to the pick-up points on the rear of the tractor by engaging the latch locking mechanism.

To disengage the latch, rotate it rearwards away from the pick-up pins on the tractor lift linkage. The attached spring will hold the latch open.

To engage the latch, rotate it towards the pick-up pins on the tractor lift linkages. The attached spring will hold the latch closed.

Detaching the sweeper collector:

- To detach the sweeper collector follow the steps in reverse order.

MAINTENANCE

Regular maintenance is essential for the continued safe operation of the machine. Correct servicing will prolong the working life of the machine and safeguard the "Hayter Warranty". Always fit genuine 'Hayter service parts' as these are accurately matched to the required duty.

IMPORTANT: The following information is given on the understanding that Hayter Limited accepts no responsibility for work carried out by a customer or for any damage thus caused, whether or not the service instructions have been misunderstood. To ensure that warranty terms are not breached, service work should only be carried out by an authorised Hayter dealer.



WARNING : PREVENT ACCIDENTS - When carrying out maintenance procedures it is essential that:

- The engine is switched off and the ignition key removed.
- The parking brake is applied.
- The safety precautions in this manual have been read and understood.



WARNING: PREVENT ACCIDENTS - The engine and rear transaxle oil will be hot after machine use. Allow the systems to cool before working on the machine, particularly before working on the engine or when changing oil or oil filters.



WARNING : PREVENT ACCIDENTS - Use hazardous substances carefully. The following fluids are identified as being hazardous;

<u>Substances</u>	<u>Assessed risk</u>
Lubricating oil	Low
Grease	Low
Petrol	High

When using any of the above fluids it is recommended that eye protection and gloves are worn and that care is taken to prevent spillage.

Avoid contact with skin; wash off spillage with soap and water.

Avoid contact with eyes; wash with running water and seek medical attention if symptoms persist.

Avoid ingestion; if swallowed seek medical attention.

CAUTION: PREVENT ENVIRONMENTAL DAMAGE - Dispose of hazardous substances correctly.

When disposing of hazardous waste products, take them to an authorised disposal site. Waste products must not be allowed to contaminate surface water, drains or sewerage systems.

CAUTION: PREVENT ENVIRONMENTAL DAMAGE - Dispose of used battery correctly. The battery has a separate collection mark. This means that the battery must not be disposed of with general waste. It must be taken to an authorised disposal site.

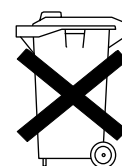

ENGINE

With the tractor on a level surface check that the engine has been filled with the correct grade of oil (SAE 30 engine oil) and to the recommended level - never overfill. Fill the fuel tank with fresh unleaded premium petrol. If the tank is more than 1/3rd full of old untreated petrol, drain and then refill. If less than 1/3rd full of old untreated fuel, top up completely with new premium unleaded petrol.

Move the throttle control to the 'Fast' position. If the engine is cold, select the choke position.

Ensure that the parking brake is engaged

Insert the ignition key and turn clockwise to the 'Engine Start' position.

If the engine fails to turn over check:

- That the battery terminals are clean and securely connected.
- That the 15 amp fuse beneath the fuel tank is securely in place and has not blown.
- That the battery is charged.

If the engine turns over but does not start, check:

- That the fuel tank is full.
- That the spark plug lead/leads is/are connected.
- That the outlet in the fuel tank is not blocked.
- That the spark plug/plugs is/are clean and set to the correct gap.
- That the fuel filter is not blocked.
- That the fuel tap is in the 'Open' position.

If the engine misfires, loses power or stalls in use check:

- That the fuel tank contains fuel.
- That the fuel filter is not blocked.
- That there are no blockages in the air intake on top of the engine cover.

IMPORTANT: If there is evidence that the engine is overheating or that engine oil consumption is excessive contact your dealer for further advice.

ENGINE OIL

IMPORTANT: Always read and follow the engine manufacturer's instructions on all matters relating to use and maintenance. Observe the oil change intervals as this will greatly enhance the service life of your engine.

The engine oil should be changed after the first 5 hours of operation.

- Start the engine and allow it to idle until warm. This will usually take about 5 minutes.
- Switch off the engine and raise the engine cover. Clean around the oil filler cap and remove.
- Locate the oil drain plug on the right hand side of the engine. It is clearly identified with a yellow cap which is fitted to the drain adaptor.
- The drain adaptor has been designed to facilitate draining of the oil.
- Remove the yellow cap.
- Fit a short length of hose to the drain adaptor nozzle and route it into an appropriate container of approximately 2 litres.
- Push the adaptor in, rotate it anti-clockwise and release to start the oil flowing.
- When the oil has completely finished draining from the engine shut off the adaptor by pushing in and rotating clockwise.
- Remove the length of tubing and replace the yellow cap.
- Refill the engine with the recommended grade of oil (SAE 30 engine oil classified for service - SF minimum) until full.

IMPORTANT:

- **Do not overfill.**
- **The use of non-recommended lubricants may lead to excessive wear and damage which will not be covered by the warranty.**

If there is evidence that the engine is overheating or that oil consumption is excessive - contact your dealer.

OIL FILTER

The oil filter is located on the left hand side of the engine and should be renewed every 100 hours of operation or annually, whichever is sooner.

FUEL AND CARBURATION**Filling the fuel tank:**

- Clean around the filler cap and neck of the fuel tank before filling.
- Fill with fresh unleaded petrol from a clean container.
- If a funnel is used ensure that it is clean.



WARNING: PREVENT ACCIDENTS - Never attempt to fill the fuel tank with fuel in the vicinity of a naked flame or where there is a risk of a spark igniting the petrol.

Fuel Filter:

The fuel filter is designed to remove micro particles and other debris from the fuel before it enters the engine.

Over a period of time the filter may become contaminated and this will result in poor fuel flow to the engine.

Periodically check the filter as follows:

- Turn the fuel flow tap to the 'Shut' position and then disconnect the fuel pipe from the engine.
- Turn the fuel flow tap to the 'Open' position and run fuel through the filter and into a container.
If fuel flows freely then the filter is performing satisfactory. Re-connect the fuel hose to the engine. It is advisable to renew the filter annually.

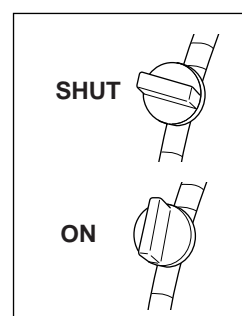
**Combustion and Cooling Air:**

The cooling fan positioned on top of the engine also provides air to the carburettor.

If the engine is difficult to start, stalls or overheats check:

- That the vents in the top of the engine cover are not blocked.
- That there is no debris caught in the cooling fan cover on top of the engine.
- That the air filter cartridges and pre-cleaner are not blocked with debris.

It is advisable to replace the filter cartridge in accordance with the engine manufacturers recommended intervals.

IMPORTANT: Keep the engine compartment free of grass, leaves and other debris.

BATTERY

The seated battery is located within the engine compartment beneath the fuel tank. With care this, will last for many years.



WARNING: PREVENT ACCIDENTS - Take care to ensure that metal objects are prevented from coming into contact with the battery terminals and bodywork.

Ensure that the screw down terminal connectors are tightly secured. Loose fittings may cause sparking.

Regularly clean the terminals and coat with petroleum jelly.

Check that the battery terminals are correctly located - Black neutral (-) and Red positive (+).

The battery should be periodically charged throughout the winter.

SPARK PLUG

Refer to the engine manufacturers handbook.

HEADLIGHTS

To replace a headlight bulb proceed as follows:

- Lift the engine cover, locate and remove the bulb holder by rotating anti-clockwise. Take care to prevent damage to the reflector.
- Remove the bulb from the holder by rotating it anti-clockwise until it is released.
- Fit a replacement bulb by reversing the steps described above.

ELECTRICAL

There is a single 15 amp fuse located beneath the fuel tank. This can be accessed by removing the small panel in the centre of the footwell.

Check the fuse after removing it from the holder. The small metal strip inside the fuse should be intact.

If the fuse has blown, check for a short circuit or a faulty electrical component.

Check:-

- That the wires to the rear electric clutch are secure and undamaged.
- That the seat switch wires are secured and undamaged.
- That the brake micro switch wires are secure and undamaged.

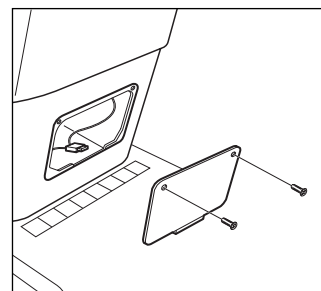

TYRES AND WHEELS

The tractor is fitted with grassland tyres designed to provide optimum traction with minimum turf marking.

For a good tractive performance check:

- That the tyres are in good condition.
- That the tyres are inflated to the recommended pressures.
- That ground speed is suited to the conditions.

Removing a front wheel:

WARNING: PREVENT ACCIDENTS - Position the tractor on a firm, level surface and engage the parking brake before attempting to remove a wheel.

- Engage the parking brake and place chocks under all wheels which are to remain on the ground.
- Place a jack under the front axle adjacent to the wheel to be removed.
- Raise the wheel to clear the ground.
- Remove the plastic cap at the centre of the wheel.
- Remove the circlip and washer and carefully slide the wheel off the stub axle.
- Replace the wheel reversing the steps described above.

Removing a rear wheel:

- Engage the parking brake and place chocks under all wheels which are to remain on the ground.
- Place a jack under the chassis adjacent to the wheel to be removed.
- Slacken off the 4 wheel nuts - Do not remove.
- Raise the wheel to clear the ground.
- Remove the 4 wheel nuts from the studs and carefully slide the wheel clear.
- Replace the wheel by reversing the steps described above.

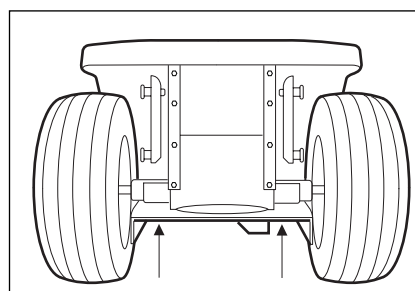

**IMPORTANT - Torque the 4 wheel nuts to 100Nm.
- Only use the recommended jacking points.**

LUBRICATION

General: All bearings used on the tractor and sweeper collector are seated for life, except where specific greasing instructions are given.

Grease Points: Use a good quality medium grease.

Lubricate the following on a monthly basis:

Front wheel bearings:	Grease nipples are located on the inside faces of the wheels adjacent to the stub axles. Turn the wheels to full lock to gain access.
Front inclined stub axle pivot brushes:	Grease nipples.
Front centre pivot:	Lubricate with engine oil.
Steering drag link brushes:	Lubricate with engine oil.
Pedal linkages/pivots:	Lubricate with engine oil.
Deck front linkages:	Lubricate with engine oil.
All belt tensioner pivots: (tractor, deck, sweeper collector)	Brush with grease.
Steering quadrant pivot:	Brush with grease.

CUTTERDECK**Replacing Primary Drive Belt:**

- Refer to the 'Cutterdeck Level Setting' procedure.
- Move the height of cut lever to the deck levelling position.
- Loosen the primary drive belt to the deck by releasing it from the drive tension pulley.
- Remove the primary drive belt and replace.
- Follow the remainder of the cutterdeck levelling procedure to ensure correct set-up and operation.

Replacing the Secondary Drive Belt:

- Follow the cutterdeck removal procedure.
- Remove the drive input cover and detach the primary drive belt.
- Remove the pulley retainer nut and withdraw the input pulley.
- Remove primary tensioner mechanism by withdrawing pivot shoulder bolt.
- Remove the belt cover retaining screws and lift off the cover.
- Take note of the secondary belt drive routing.
- Rotate the tensioner assembly to reduce belt tension and remove the drive belt.
- Replace the drive belt with care and ensure that it is routed and tensioned correctly.
- Follow the previous steps in reverse order to fully assemble the cutterdeck.
- Assemble the cutterdeck to the tractor by following the cutterdeck attachment procedure.

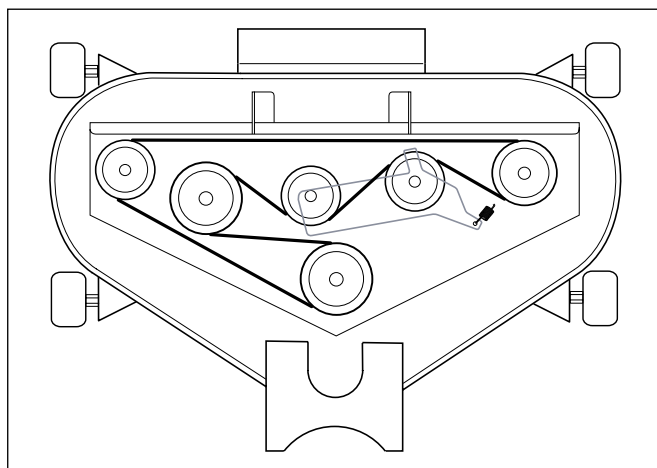

CUTTERDECK**Continued.****Cutterdeck Removal:**

- Refer to the 'Cutterdeck Lever Setting' procedure and move the height of cut lever to the deck levelling position.
- Remove the R-clips and washers from the rear suspension brackets.

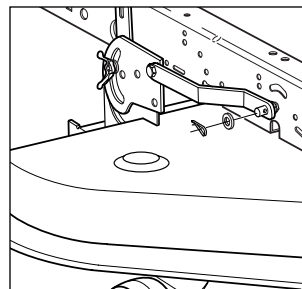

- Remove the R-clips and washers from the rear lift links.

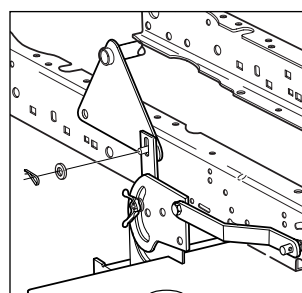

- Disconnect the extension spring from the chassis.

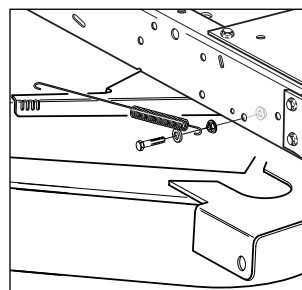

- Remove the R-clip from the hanger rod. Push the hanger rod through and then withdraw from between the hanger brackets. Allow the front suspension bracket to hinge forward and lay on the ground.
- Remove the primary drive belt from the elective clutch output pulley.
- Pull the cutterdeck assembly away from beneath the tractor.

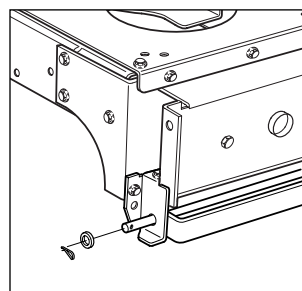
**Cutterdeck Attachment:**

- Follow the cutterdeck removal procedure in reverse order to install the cutterdeck.
- Ensure that the primary drive belt is correctly routed and located.
- Follow the 'Cutterdeck Level Setting' procedure to ensure correct set-up and operation.

POWERED SWEEPER COLLECTOR

Replacement of the Primary Drive Belt:

- Refer to the 'Attaching/Detaching the Sweeper Collector'.
- Follow the procedure and detach the sweeper collector sufficiently to allow removal of the primary drive belt.
- Fit a replacement drive belt and re-attach the sweeper collector as described.

Replacement of the Brush Drive Belt:

- Remove 2 M10 Nyloc nuts and plain washers and remove the plastic side guard.
- Hold back the tensioner assembly and remove the brush drive belt.
- Fit a replacement drive belt and ensure that it is correctly routed and tensioned.
- Replace the side guard.
- Replace the M10 fastenings and tighten securely.

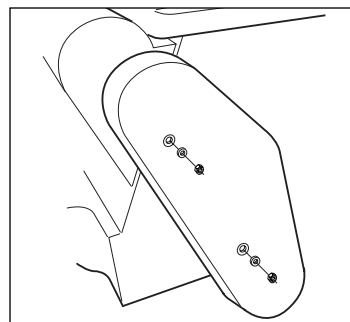

Replacement of the Bristle Sections:

- Remove the hopper assembly and gain access to the brush assembly through the rear of the sweeper unit.
- Loosen the clamps at each end of the brush stack assembly.
- Slide each brush section aside as required to enable the individual bristle holder sections to be withdrawn by sliding from the location slots.
- Replace bristle sections as required.
- Slide the brush sections together until they are tightly packed in the centre of the square shaft.
- Re-position and re-tighten the end clamps to secure the brush stack assembly.
- Replace the hopper assembly.

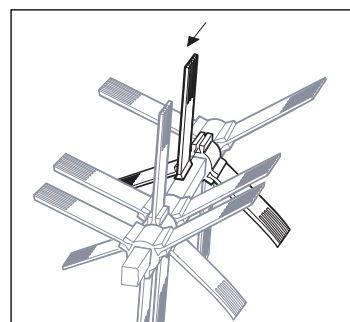

GRASS CUTTING FAULTS

FAULT	POSSIBLE CAUSE	REMEDY
Steps in cut grass height	One end of cutterdeck out of ground contact. Grass build-up under cutterdeck. Tyre pressures incorrect.	Reset cutterdeck levelling. Remove grass. Inflate to correct pressure.
Uneven/poor cut performance.	Undulating ground contours. Cutterblades worn or damaged. Cutterblades out of balance. Cutterdeck gauge wheels damaged. Inconsistent height of cut settings. Slow cutterblade rotational speed.	Change direction of cut. Sharpen or replace as necessary. Replace as necessary. Inspect and replace as necessary. Check and re-adjust height of cut settings. Check that engine speed is set to maximum.
Scalping.	Undulations too severe for height of cut settings.	Raise height of cut.
Areas of uncut grass at point of overlap between adjacent blades.	Turning too tightly Mower sliding sideways when travelling across face of slope.	Increase turning radius. Mow up/down slope.

TROUBLE SHOOTING

FAULT	POSSIBLE CAUSE	REMEDY
The engine will not start with ignition key.	Cutterdeck switch is engaged. Parking brake is not applied. Battery is flat. Faulty electrical connections. The seat switch is faulty. Fuse is blown. Sweeper switch is engaged.	Move cutterdeck switch to disengaged. Set parking brake. Charge the battery. Trace and correct fault. Replace switch. Replace fuse. Move sweeper switch to dis-engaged.
Flat Battery.	Terminal connection loose or corroded. Loose or defective alternator belt. Defective battery. Electrical short circuit.	Clean and tighten terminal connections. Recharge battery. Re-tension or replace drive belt, refer - ENGINE HANDBOOK. Recharge battery. Replace battery. Trace short circuit and make good.
Engine will not start, is difficult to start or fails to continue running.	Operator is not seated correctly. Fuel tank is empty. Fuel is stale. Air cleaner is dirty. Spark plug cable is loose or disconnected. Spark plug is pitted, fouled, or gap is incorrect. Choke is not closing. Dirt in fuel filter. Idle speed is too low or mixture is incorrect. Air vents in engine cover blocked with debris. Fan cover on top of engine blocked with debris. Fuel shut-off valve is closed.	Sit on the seat. Fill fuel tank with unleaded petrol. Drain and fill with fresh petrol. Clean or replace air cleaner elements. Secure cable on spark plug. Install new, correctly adjusted spark plug. Adjust throttle cable. Replace fuel filter. Adjust carburettor idler speed and mixture. Clear vents of debris. Clear cover of debris. Open fuel shut-off valve.

TROUBLE SHOOTING

FAULT	POSSIBLE CAUSE	REMEDY
Engine overheats.	<p>Engine load excessive.</p> <p>Engine oil level is low.</p> <p>Cooling fins and air passages under engine blower housing are plugged.</p> <p>Air vents in engine cover blocked with debris.</p> <p>Fan cover on top of engine blocked with debris.</p>	<p>Reduce ground speed.</p> <p>Add oil to engine.</p> <p>Remove obstruction from cooling fins and air passages.</p> <p>Clear vents of debris.</p> <p>Clear cover of debris.</p>
Tractor does not drive.	<p>Traction belt is worn, loose or broken.</p> <p>Traction belt is off the pulley.</p>	<p>Contact Authorised Service Dealer.</p> <p>Contact Authorised Service Dealer.</p>
Engine loses power.	<p>Engine load is excessive.</p> <p>Air cleaner is dirty.</p> <p>Oil level in crankcase is low.</p> <p>Air vents in engine cover blocked with debris.</p> <p>Fan cover on top of engine blocked with debris.</p> <p>Spark plug is pitted, fouled or gap is incorrect.</p> <p>Vent hole in fuel cap is plugged.</p> <p>Dirt in fuel filter.</p> <p>Dirt, water or stale fuel is in fuel system.</p>	<p>Reduce ground speed.</p> <p>Clean air cleaner elements.</p> <p>Add oil to crankcase.</p> <p>Clear vents of debris.</p> <p>Clear cover of debris.</p> <p>Install new, correctly adjusted spark plug.</p> <p>Clean or replace the fuel cap.</p> <p>Replace fuel filter.</p> <p>Contact Authorised Service Dealer.</p>
Abnormal vibration.	<p>Cutterblade(s) bent or unbalanced.</p> <p>Blade mounting screws are loose.</p> <p>Engine mounting bolts are loose.</p> <p>Loose engine pulley, idler pulley or blade pulley.</p> <p>Engine pulley is damaged.</p> <p>Blade drive belt is damaged.</p>	<p>Install new cutterblade(s)</p> <p>Tighten blade mounting screws.</p> <p>Tighten engine mounting bolts.</p> <p>Tighten the appropriate pulley.</p> <p>Contact Authorised Service Dealer.</p> <p>Install new blade drive belt.</p>

TROUBLE SHOOTING

FAULT	POSSIBLE CAUSE	REMEDY
Blade(s) do not rotate.	Blade drive belt is worn, loose or broken. Blade drive belt is off pulley.	Install new blade drive belt. Install blade drive belt and adjust for correct tension.
Uneven cutting height.	Tyre pressures are incorrect. Tractor is not level. Grass build-up under cutterdeck. Blade mounting screws are loose. Blade drive belt tension is incorrect.	Check and adjust tyre pressures. Adjust the height adjustment cable rod assembly. Remove grass. Tighten blade mounting screws. Adjust blade drive belt.

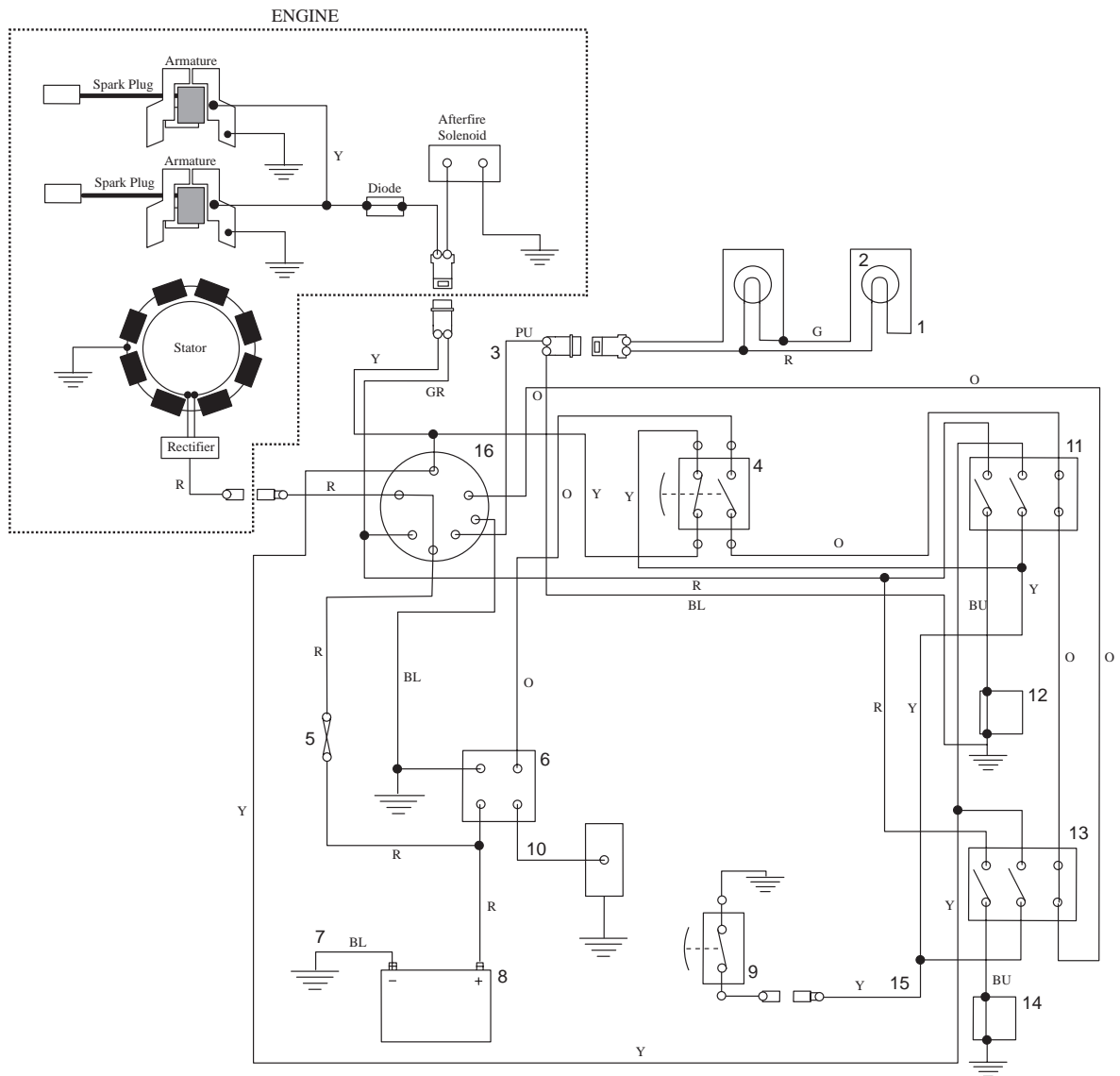

No.	DESCRIPTION.	Parts No.	Wire Colour Code
1	Harness - Light Wire	MU250x106	G Green. BU Blue.
2	Bulb - Light	MU90084	R Red. BL Black.
3	Harness - Front	MU250x108	O Orange. PU Purple.
4	Switch - Limit	MU94136	Y Yellow. GR Grey.
5	Fuse - 15amp	MU54212	
6	Solenoid	MU7766224	
7	Cable - Battery Ground	MU24x3	
8	Battery	150011	
9	Switch - Seat Sensor	MU24x31	
10	Cable	MU24x31	
11	Switch - Cutterdeck	MU1001502	
12	Clutch - Cutterdeck	MU1001404	
13	Switch - Sweeper	MU094927	
14	Clutch - Sweeper	MU1001403	
15	Harness - Rear	MU250x109	
16	Switch - Ignition	MU92556	

Example 2 Colour Wire:

